



INSTRUCTION MANUAL

Manual SMT Stencil Printer

Model: X-PRINT305

P/N X-DOC102

21-01-12

650 Scranton Pocono Hwy.
Covington Twp., Pa 18444, USA
Tel: (570) 282-7589 Fax: (570) 282-1426
E-Mail: bokar@bomir.com
www.bokar.com and www.bomir.com



Table of Contents

	Page
1. Introduction	3
2. Specifications	3
3. Unpacking and Set-Up	5
4. Controls And Adjustments	6
5. Using the Printer	7
6. Option	8
7. Warranty	8

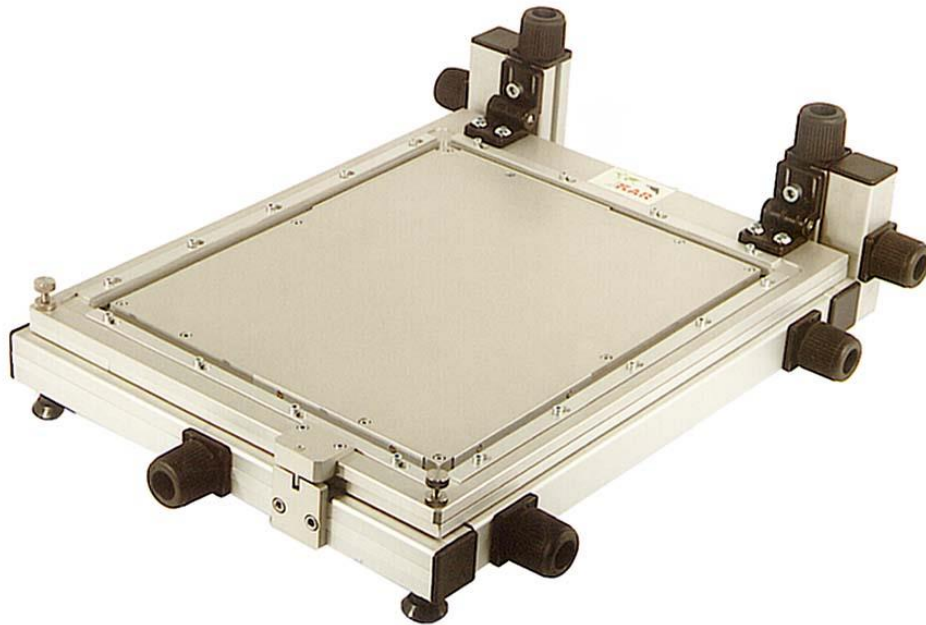

FIG. 1 VIEW OF THE SYSTEM

1. Introduction

CONGRATULATIONS on your purchase of the X-PRINT305 Manual Stencil Printer.

The X-PRINT305 printer can easily print solder pastes, adhesives, or solder masks on any surface mount technology printed circuit PCB. In addition, your X-PRINT305 printer will give you extremely accurate and repeatable results never before attainable by a manual application process.

2. Specifications

Base adjustment (x, y axis)	5 mm
Base adjustment (z axis)	5 mm
Base adjustment (θ)	2°
Adjustment accuracy	0.03 mm
Squeegee	1 standard
Dimensions	483x600x200 mm
Max. Working area (PCB size)	305x380 mm
Weight	15 kg

Note 1)

The printer does not included a metal stencil. This is required for specific size and mounting holes. Please refer to the illustration 1 on page 4 for the external dimensions.

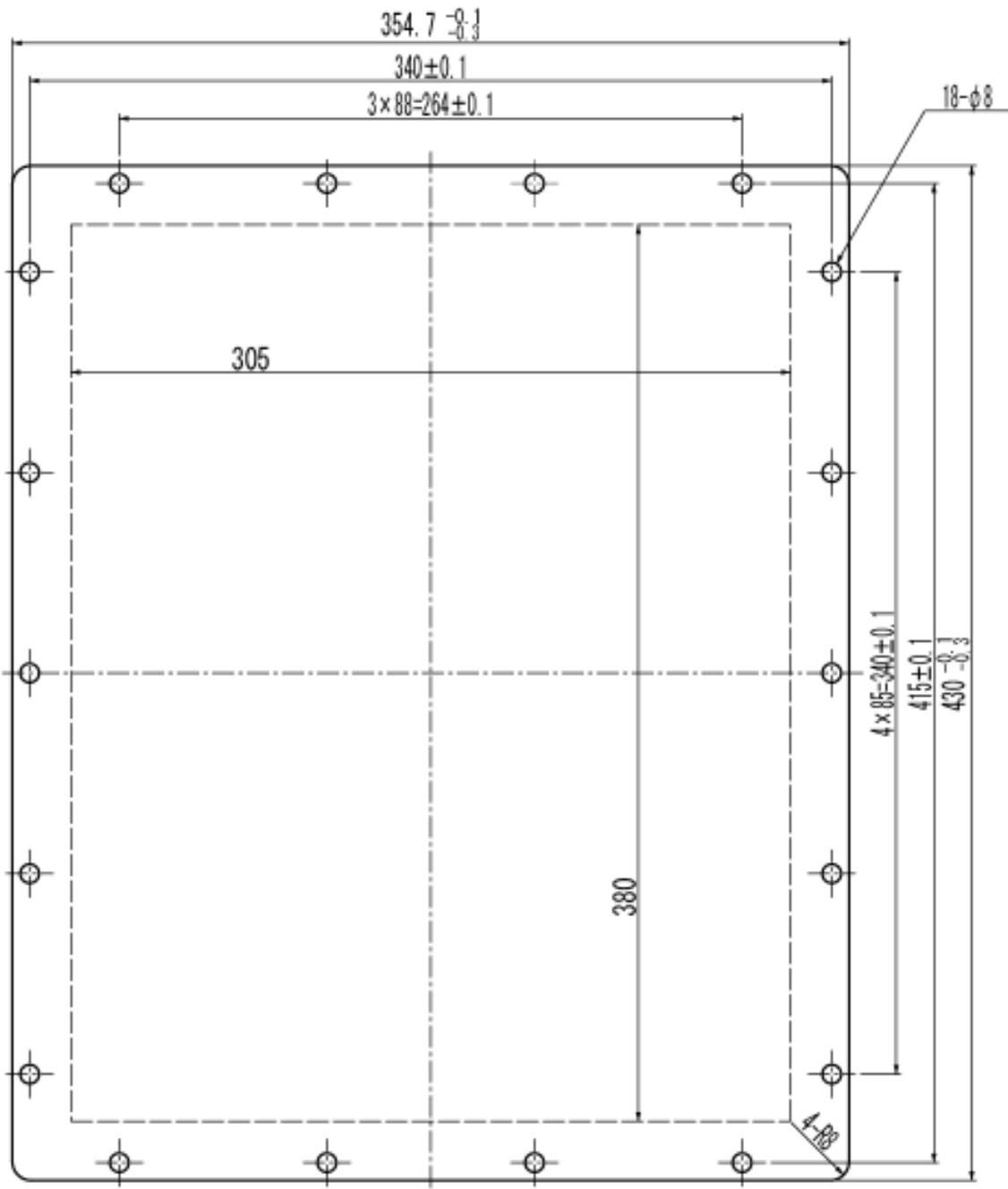

FIG.2 X-PRINT305 Metal Stencil Dimensions (mm)

3. Unpacking and Set-Up

① Unpacking

Unpack all items from the box. The box should contain the following:

- Stencil Printer X-PRINT305
- Application Squeegee X-PRINT305RA
- Hex. Key set
- User's Manual

IMPORTANT: Be sure that all the above items are included in the box. Inspect each item for any damage that may have occurred during shipping. Notify your supplier immediately if there are any damaged or missing parts.

② Metal Stencil Mounting

- 1) Loosen the screws holding the metal stencil fixing plates (4 locations), and remove the plates.
- 2) Remove the plates by moving them in the direction of the larger opening side of the mounting holes.
- 3) Place a metal stencil into the frame.
- 4) Remount the metal stencil fixing plates, slide them over the screw holes and tighten the screws.

③ Metal Stencil Pattern Location

- 1) In order to ensure proper mounting of a metal stencil, it is important that you supply the manufacturer of the metal stencil with a copy of the mounting template for your printer model included with the metal stencil. This template will show exactly what size the metal stencil should be and the exact locations of the holes. (Refer to the illustration 1 for the template size.)
- 2) It is important that you set the position of the metal stencil pattern in the middle of the metal stencil.
- 3) The PCB's corner must start 25mm down from the top and 25mm in from the left side of metal stencil in order to properly align it in the holder. Please note that these distances may vary slightly since the corner is adjustable in the X and Y direction (Axis).
- 4) The metal stencil mounting holes should be made at the same time the pattern is being etched. It is not recommended that the mounting holes be made after the metal stencil has been manufactured.

4. Controls and Adjustments

Refer to illustration 2 and the following table to help define the various adjusting knobs.

KNOBS	NAME	FUNCTION
-------	------	----------

A	Z-axis adjusters (frame height)	Used to control the height of the metal stencil proportional to the PCB. Each side may be independently adjusted.
B	X-axis and θ adjusters	Used to move the PCB sideways and circular directions. Each side may be independently adjusted.
C	Y-axis adjuster	Used to move the PCB forward or backward.
D	Frame lock (Z-axis)	Used to lock Z-axis adjusters.
E	Frame leveling adjuster	Used in conjunction with Knob A to adjust the height of the metal stencil. Proper adjustment will make the metal stencil coplanar while printing.

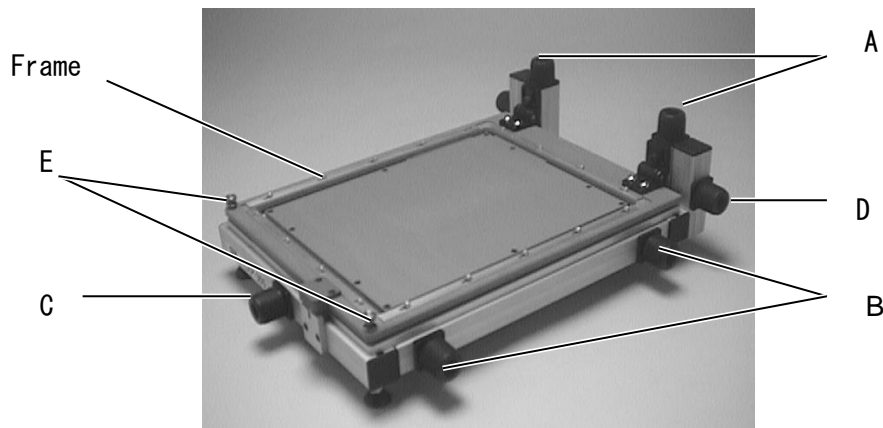

FIG.3 X-PRINT305 Controls & Adjustment

5. Using the Printer

- ① Place a PCB on the PCB holder at the position following the pattern on your metal stencil (Upper left-hand or right-hand corner), so that the PCB is square with the corner.
- ② Lower the metal stencil (Frame) over the PCB slowly.
- ③ Use the adjuster knobs to locate the metal stencil directly over the PCB pattern. The X adjusters are used to move the PCB sideways when turning both of them simultaneously (One click moves it 0.03mm.). When turning each adjuster, the PCB will move in a circular direction. In the same way, the Y adjusters are used to move the PCB forward or backward.
- ④ The Z-axis adjusters are used to adjust for various PCB thickness. Z-axis adjustment will also affect the amount of solder cream printed on PCB.
- ⑤ The quantity of solder paste to be applied on the PCB should spread out larger than the PCB size. Apply the solder paste on the top of the metal stencil. Hold the squeegee firm at roughly 45-degree angle to the PCB, and make one slow sweep across the PCB using leading edge of the squeegee.
- ⑥ Lift up the metal stencil (Frame) and take out the printed PCB. Be careful not to touch the solder paste on the PCB.
- ⑦ It is recommended that you do several practice prints before actually printing a PCB. A good practice technique is to place some type of semi-transparent paper over the PCB, print onto the paper and check alignment and the amount of solder cream printed.

After you are satisfied with the result in Step 5, start printing PCBs.

6. Options

The following optional items are available.

Item	Model	Remarks
Frame	X-PRFR	Spare frame with mounting bracket.
Squeegee	X-PRRA	Spare squeegee
Cleaner	LXP-CL150	Metal Stencil Cleaner (500ml/bottle)

7. Warranty

- X-PRINT305 Manual Stencil Printer is under warranty for 1 year from the date of purchase for all parts and repair labor excluding squeegee.
- Bokar International cannot accept responsibility for damage to the X-PRINT305, products and/or other equipment or tools due to incorrect setting or misuse by the operator. Read carefully this User's manual prior to use.



BOKAR International
650 Scranton Pocono Hwy.,
Covington Twp. PA 18444, USA

Tel: (570) 842-2812 Fax: (570) 842-4290

E-mail: bokar@bomir.com

www.bokar.com

Other pages of Bokar International Products:



SMT: www.Assembly-SMT.com www.FineRework.com www.X-Reflow306.com,
www.X-1003.com www.SMTrepair.com www.SMTFocus.com
www.SMTdispenser.com www.BestBatchOven.com www.SMT-tool.com

ESD: www.ESDapparel.com www.ESDmeters.com www.ESDpackaging.net
www.ZeroCharge.net www.No-Stat.com www.ESDchair.com
www.ESDIabcoats.com www.ESDcarts.net www.ESDbrushes.com

Other: www.SuperiorScrewdrivers.com www.Super-Iron.com

Latest Additions: www.PCBprototypingRobot.com www.ProportionAir.com

www.FumeXtraction.com and www.ULT.de (We represent ULT in the USA, Canada and Mexico)